



CAST IRON VALVES

GENEBRE PART: 2525 2 PCE FULL BORE BALL VALVE FLANGED PN16 DIRECT MOUNT



SPECIFICATIONS

| | |
|---|---|
| 1 | Material Cast Iron GG-25 |
| 2 | Flanged ends according to DIN 2501 PN16 |
| 3 | Max working pressure 16 BAR (See PxT chart below) |
| 4 | Max Temperature -30°C to +180°C |
| 5 | Full bore, direct mount |
| 6 | Direct mount ISO5211 patent 9900474 respected |
| 7 | R PTFE seats & PTFE seals |

DIMENSIONS

| AVOL | SIZE | L | H | h | L1 | Wt |
|---------|--------|-----|-----|------|------|-------|
| REF | mm | mm | mm | mm | mm | Kg |
| 2525 04 | 1/2" | 115 | 49 | 9.5 | 130 | 2.30 |
| 2525 05 | 3/4" | 120 | 54 | 9.5 | 130 | 2.90 |
| 2525 06 | 1" | 125 | 60 | 11.5 | 170 | 4.00 |
| 2525 07 | 1 1/4" | 130 | 73 | 11.5 | 170 | 5.00 |
| 2525 08 | 1 1/2" | 140 | 78 | 15.5 | 220 | 7.00 |
| 2525 09 | 2" | 150 | 86 | 15.5 | 220 | 9.40 |
| 2525 10 | 2 1/2" | 170 | 98 | 18.5 | 284 | 13.00 |
| 2525 11 | 3" | 180 | 113 | 18.5 | 284 | 17.20 |
| 2525 12 | 4" | 190 | 136 | 18.5 | 360 | 22.60 |
| 2525 13 | 5" | 325 | TBC | TBC | 447 | 36.0 |
| 2525 14 | 6" | 350 | TBC | TBC | 560 | 49.5 |
| 2525 16 | 8" | 400 | TBC | TBC | 1000 | 98.50 |

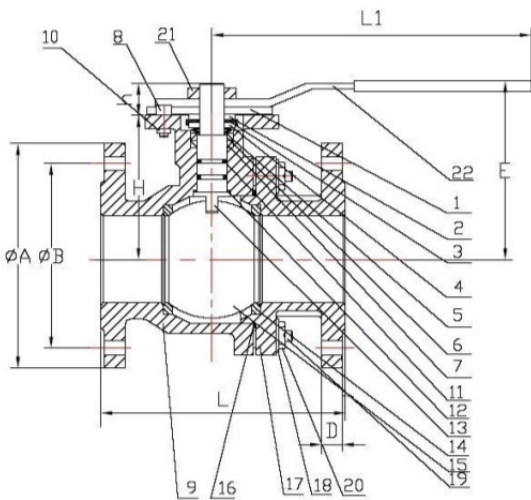

TORQUE FIGURES *excluding safety

| SIZE | ISO:5211 | STEM SQ mm | TORQUE Nm* |
|--------|----------|------------|------------|
| 1/2" | F03/04 | 9 | 5 |
| 3/4" | F03/04 | 9 | 8 |
| 1" | F04/05 | 11 | 15 |
| 1 1/4" | F04/05 | 11 | 20 |
| 1 1/2" | F05/07 | 14 | 30 |
| 2" | F05/07 | 14 | 40 |
| 2 1/2" | F07/10 | 17 | 50 |
| 3" | F07/10 | 17 | 75 |
| 4" | F07/10 | 17 | 115 |
| 5" | F07/10 | 17 | 150 |
| 6" | F10/12 | 22 | TBC |
| 8" | F12/14 | 27 | 545 |

PRESSURE/ TEMPERATURE CHART

